



**SOUTHERN MAINE TRACTOR CLUB
MARCH 2008**

WEBSITE: WWW.SOMETRACTORCLUB.ORG

President's Corner

I am not sure whether you will receive this before the 9th but the time change is going to be nice. Daylight in the evening so you can do outside work after supper.

Before I forget Roxanne has started a club website. There is some work to do yet but it is a start. If you don't get this newsletter, you can read it on the website. www.sometractorclub.org
In the minutes of the last meeting, the pulling committee is not going to mandate wheelie bars. It was recommended. Wheelie bars have to be strong enough to support your tractor and it is recommended that they be no more than ten inches off the ground to prevent the front end from coming up too far. The 2500 lb class will be a 2600 lb class to allow installation of wheelie bars and also to allow additional weight on the front end of the tractor.

Have a good Easter,
Frank Bumford

TREASURER'S REPORT

January 2008

BALANCE 12/31'7	4313.35
1/4'8 acme scale	-2460.00
1/31'8 newsletter	-73.83
BALANCE 1/31'8	1779.52

February 2008

BALANCE 1/31'8	1779.52
2/12'8	430.00
BALANCE 2/29'8	\$2209.52

LENNY TIBBETTS WILL BE HAVING SURGERY ON HIS HIP

MARCH 11TH.

HIS MAILING ADDRESS IS:

PO BOX 246 BERWICK, ME 03901

Punky's Tidbits

The potluck/meeting at the Alfred American Legion Hall on February 24th was a huge success. Good food, great ideas shared and the raffle was drawn. Winners were Chris Libby- generator, George Worthley- chainsaw and Dennis Knight - \$50.00. Congrats to all and many many thanks to everyone who participated. Highlights were the 2008 pulling schedule, 2008 pulling rules, the points system and the new scales were on display for all to see. Go to our website to see pictures of the new scales.

Speaking on the website... check out the site Roxanne is building for the antique tractor division. It is great! The two websites will be linked together and I think that will work out well.

I am looking forward to the upcoming season and the pulls that, we the garden tractor division and the antique tractor division have together. We can all have fun and play together.

The garden tractor division is now looking for a boxed trailer to store and transport our supplies in. Frank and Roxanne have one that we will be checking on.

Thank you goes out to Kenny Noble and Ryan Sepiel for donating the 50/50 money that was won at our at our pot luck.

Our next potluck/meeting is scheduled for April 20th at the Alfred American Legion. 12 to eat and meeting to follow. All are welcome. And Vera is making shepard's pie!!! See you all there.
Garden Tractor Pulling Chairman Punky Noble and Vice Chairman John Martel

Southern Maine Tractor Club Meeting
Bob Hanson Garage
2/17/2008

The meeting was called to order by the President, Frank Bumford. He welcomed everyone and thanked them for coming. He welcomed the two new members of the Pulling Committee Willie Ball and Doug Parker.

Secretary's Report

The minutes of the previous meeting were read. Dick Smith made a motion to accept the minutes as read. It was seconded and passed.

Treasurer's Report

The Treasurer's report was available for everyone to have. There was a question regarding the postage and mailing categories. Roxanne explained that the mailing was the newsletter, which includes copies and the postage was the stamps that are used for individual letters, such as returning membership cards. Dick Smith made a motion to accept the treasurer's report as written.

Garden Tractor Report

Punky told the group that the new scales had arrived and would be at the 2/24 meeting, that was a potluck dinner and with a meeting to follow and all are welcome. The group is now raising money for a trailer to haul the scales in.

Old Business:

None brought up.

New Business:

Greg Haley spoke for the Antique Tractor Pulling Committee on the wheelie bar issue. The Committee has decided to strongly suggest wheelie bars this year. Frank Bumford stated that the 2500 lb class will be changed to 2600lb class so that this class can add the wheelie bars and arrange their

weights properly. The committee will do more policing of this issue this year and may disqualify anyone who is deemed too high. They will be working on the policy for this. In this newsletter there will be a web address for a seller of wheelie bars and the specs used by the NTPA.

The pulling committee will choose their own chairperson. Boomy has 2 years left on his term. Greg Haley has three years and Doug, Willie and Dan each have 1 year term.

The calendar of events is a work in progress. Pete Ellis will get the information on the Scarborough parade, Doug will get information on the Windham parade and Willie Whitten will get the information on the Westbrook parade. We set a date for a pull at Dan Higgan's Farm in Topsham as June 28th with the 29th as a rain date. Frank will be finding out the status of Rochester Fairgrounds and working more on the schedule. He will also contact Lennie as to the status of the sled.

Marie Ball made a motion to adjourn at 3:02 pm.

Respectfully submitted,
Roxanne Bumford

INFORMATION ON WHEELIE BARS

They can be purchased from:
Denny's Carb Shop Tractor Products
973-368-2304

Web site: www.dennyscarbshop.com

Cost is about \$250.00

This is information that I found on several different websites that I thought that I would share.

It is recommended that the wheelie bars not be attached to the draw bar in any way.

The wheelie bar pads are to be a minimum of 5" X 5", no more than 10" above ground and the front edge of the pads must be behind the rear most part of the tire. All bars must support the tractor in its heaviest class. This will be tested by jacking up one pad at a time.

. SAFETY-". Wheelie bars must have 25 square inches of pads and be spaced no closer than 20" apart. Wheelie bars must be rigid and be able to be jacked up on the pad in the heaviest class being pulled by that tractor. A diagram of tech approved wheelie bars are attached to these rules. I

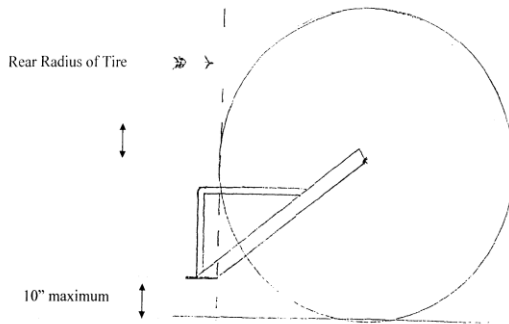

WHEELIE BARS

Wheelie bars should hold the weight of the tractor in its heaviest weight class. Wheelie bars are not to be attached to the draw bar. Wheelie bars must be a minimum length of: the front edge of the stabilizer pad can be no farther forward than the rear radius of the tire. The pads must not be more than 10" off the ground and must be a minimum 5"x5"x1/4" and a minimum of 20" apart.

**FOR SALE:
1984 JOHN DEERE LAWN MOWER
WITH WHEELIE BARS, WEIGHTS
AND A MOWER DECK. HAS MANUAL
TRANSMISSION AND A KOHLER
ENGINE
CONTACT JERRY VIGUE
207-892-5919**

PLEASE SEND TWO NAMES FOR THE MEMBERSHIP CARDS AND YOUR CURRENT ADDRESS.

THE DUES ARE \$20.00 FOR A FAMILY.
\$25.00 FOR A SPONSOR.

THE INSURANCE WILL BE \$15.00 FOR A SINGLE PULLER OR \$30.00 PER FAMILY.

PLEASE MAKE YOUR CHECK OUT TO:

SOUTHERN MAINE TRACTOR CLUB

And send to: Southern Maine Tractor Club

PO BOX 248

Lebanon, Me 04027

2008 Dues are now due.